

PLAN

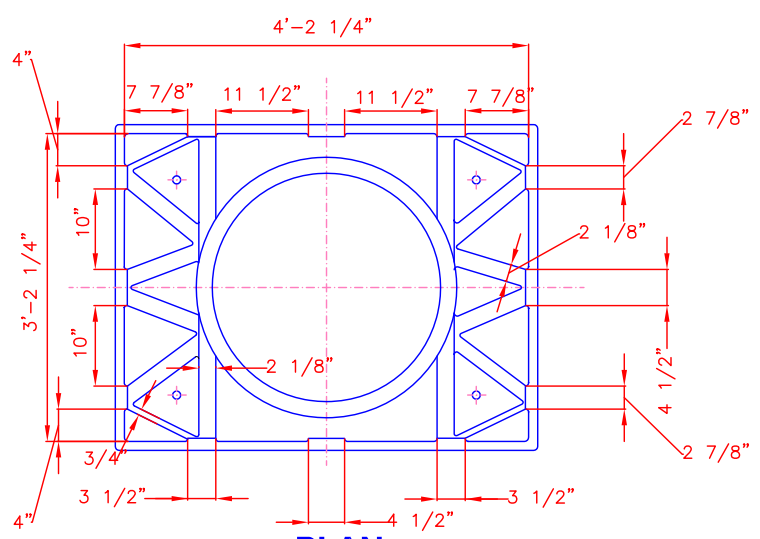

**PLAN
UNDERSIDE OF COVER**

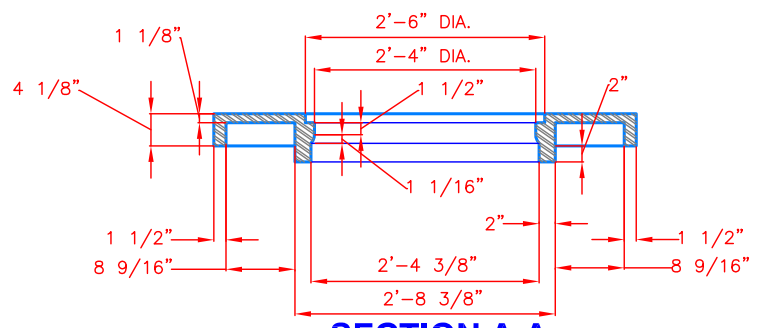

SECTION A-A

Location: \\bwscc.org\public\Personal\donohoe\Desktop\F-06 - G Frame and Cover-New.dwg
Plotted on: Wednesday, February 13, 2019 - 7:42 AM by Donohoe, William



**Boston Water and
Sewer Commission**
980 HARRISON AVE., BOSTON, MA 02119
(617) 989-7000 www.bwsc.org

G FRAME COVER

Scale: Not To Scale

DATE:
Feb. 13, 2019

DETAIL NO.
F-06a

NOTE:
 ALL CASTINGS SHALL BE
 MANUFACTURED FROM GRAY IRON
 CONFORMING TO ASTM A48 CLASS 35B
 AND/OR AASHTO M105 CLASS 35B.

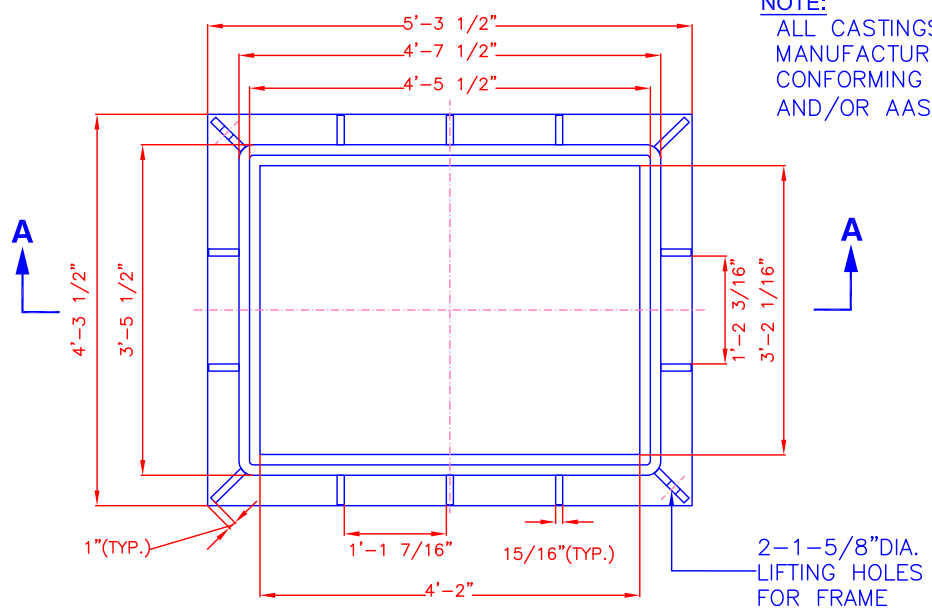

PLAN

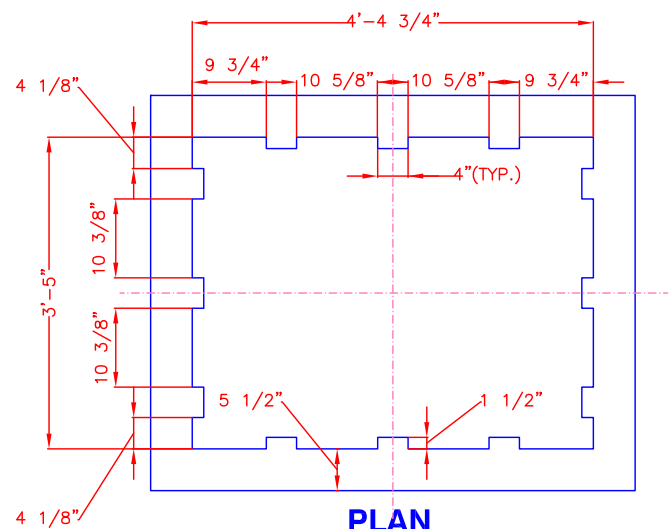

**PLAN
 UNDERSIDE OF FRAME**

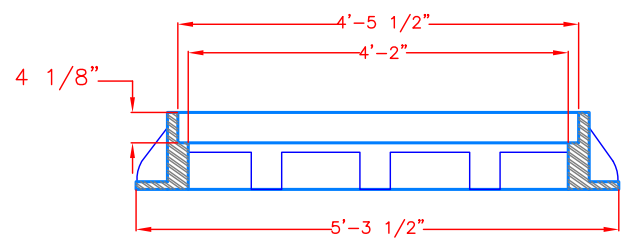

SECTION A-A

Location:Filename: V:\eng\ACAD_STD\Technical\Details\F - Castings\F-06 - G Frame and Cover.dwg
 Plotted on: Thursday, January 23, 2014 - 9:24 AM by Donohoe, William



**Boston Water and
 Sewer Commission**
 980 HARRISON AVE., BOSTON, MA 02119
 (617) 989-7000 www.bwsc.org

G FRAME
 Scale: Not To Scale

DATE:
 Jan. 14, 2014

DETAIL NO.
F-06b